

# VENTI™ Fluxo

## SINGLE ROOM HEAT RECOVERY

Installation, maintenance & user manual

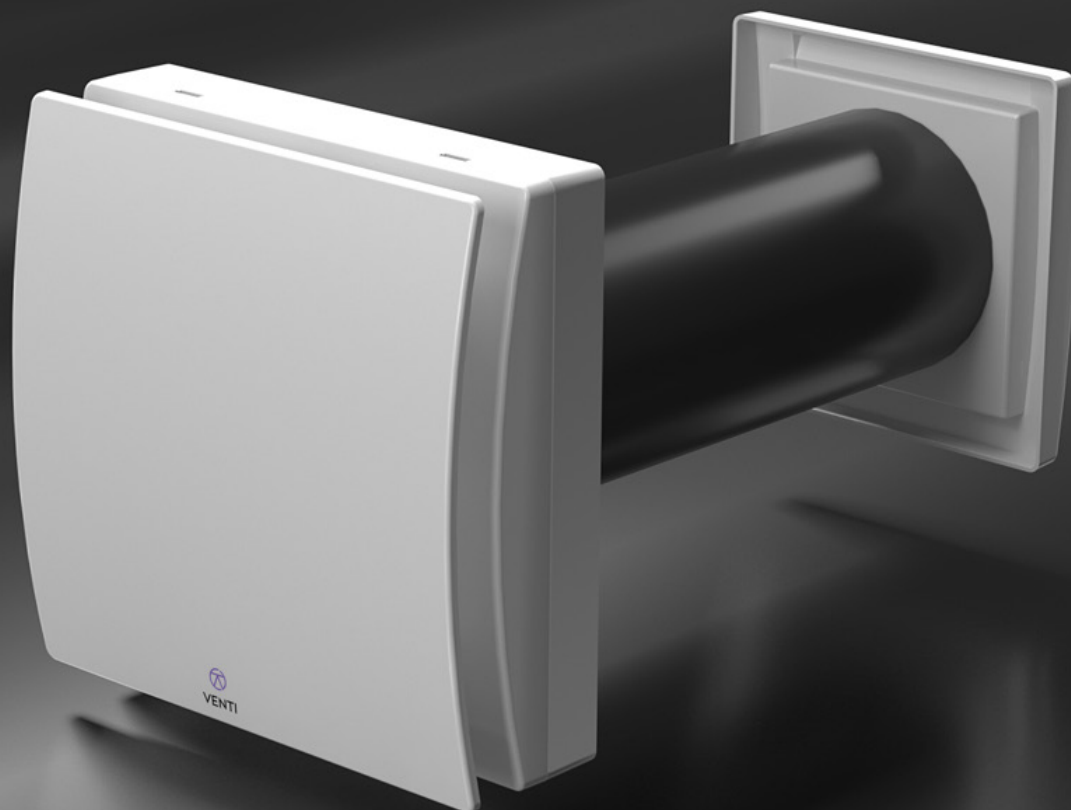

Applicable to the following VENTI Fluxo models:

PRODUCT CODE

**FL1-100-WH**

**FL1-150-WH**

# CONTENTS

PLEASE KEEP THESE INSTRUCTIONS WITH THE PRODUCT.  
Please read this manual fully prior to installing the MVHR unit.

1.0	Introduction.....	3
1.1	Model Variations.....	3
1.2	Product Guarantee.....	3
2.0	Safety.....	4
2.1	General Safety.....	4
2.2	Responsibility of the Installer.....	5
2.3	Responsibility of the Occupant.....	5
3.0	Specifications/ Dimensions.....	5
3.1	Product versions.....	5
3.2	Detailed Specification.....	5
3.3	ErP Directive - Regulations 1253/2014 - 1254/2014.....	6
4.0	Operation.....	7
4.1	Synchronisation.....	7
4.2	Jumper positions.....	8
4.3	Disposal and recycling.....	8
5.0	Installation and figures.....	8
	Notes.....	17
	Customer Support.....	19

## IMPORTANT

This appliance is not intended for use by persons (including children) with reduced physical sensory or mental capabilities, or lack of experience and knowledge, unless they have been given supervision or instruction concerning use of the appliance by a person responsible for their safety.

## 1.0 Introduction

A continuous running, low energy, ultra-quiet, alternate flow supply and extract fan with heat retention for use in habitable areas such as living rooms, bedrooms, dining rooms, basements and hallways.

The unit provides ventilation and reduces indoor air pollutants and humidity levels. The unit is ideal for tackling problems associated with condensation dampness such as mould growth.

It is recommended that two units are installed in pair: when one unit is pulling, the other is pushing.

Pair of units can be installed in the same room or in different rooms (i.e. living room and bedroom). The unit is suitable for installation on an outside wall.

The unit should operate continuously, and only be stopped for maintenance or service. When heat exchange is not useful (for example in mid-seasons when indoor and outdoor temperatures are similar), or when heat exchange is not recommended (for example with the option “summer free cooling”), it is recommended to set the unit in “extract-only” or “intake-only” mode and NOT to switch it off.

## 1.1 Model Variations

PRODUCT CODE

FL1-100-WH

FL1-150-WH

## 1.2 Product Guarantee

This product is guaranteed against defects for a period of 2 years from date of purchase with the first year covering parts and labour and the remaining year covering parts only.

In the instance of a defect, Venti may repair the product, replace the product free of charge or refund the cost of the product at Venti’s own discretion. In terms of installation, operation and maintenance please follow all instructions provided. If this product has been misused, not properly maintained or handled carelessly it may lead to this guarantee being declared void.

Venti does not accept liability for damage caused by non-observance of the installation instructions.

Service activities must be carried out by Venti or by competent installers using original Venti parts. This guarantee does not affect your statutory right as a consumer.

Venti operate a policy of continuous innovation and improvement and thus reserve the right to alter product specifications and appearances without notice.

## 2.0 Safety

The following information must be read carefully to ensure safe installation and operation of the unit.

### 2.1 General Safety

- ✓ The device should not be used for applications other than those specified in this manual.
- ✓ After removing the product from its packaging, verify its condition. In case of doubt, contact a qualified technician. Do not leave packaging within the reach of small children or people with disabilities.
- ✓ Do not touch the appliance with wet or damp hands/feet.
- ✓ This appliance can be used by children aged 8 years old and above and persons with reduced physical, sensory or mental capabilities or lack of experience and knowledge if they have been given supervision or instruction concerning use of the appliance in a safe way and understand the hazards involved. Children should not play with the appliance. Cleaning and user maintenance should not be performed by children without supervision.
- ✓ Do not use the product in the presence of flammable vapours, such as alcohol, insecticides, gasoline, etc.
- ✓ If any abnormalities in operation are detected, disconnect the device from the mains supply and contact a qualified technician immediately. Use only original spare parts for repairs.
- ✓ The electrical system to which the device is connected must comply with regulations.
- ✓ Before connecting the product to the power supply or the power outlet, ensure that:
  - the data plate (voltage and frequency) corresponds to those of the electrical mains
  - the electrical power supply/socket is adequate for maximum device power.  
If not, contact a qualified technician.
- ✓ The device should not be used as an activator for water heaters, stoves, etc., nor should it discharge into hot air/fume vent ducts deriving from any type of combustion unit. It must expel air outside via its own duct.
- ✓ Operating temperature: -20°C up to +50°C.
- ✓ The device is designed to extract clean air only, i.e. without grease, soot, chemical or corrosive agents, or flammable or explosive mixtures.
- ✓ Do not leave the device exposed to atmospheric agents (rain, sun, snow, etc.).
- ✓ Do not immerse the device or its parts in water or other liquids.
- ✓ Turn off the main switch whenever a malfunction is detected or when cleaning.
- ✓ For installation an omni polar switch should be incorporated in the fixed wiring, in accordance with the wiring regulations, to provide a full disconnection under overvoltage category III conditions (contact opening distance equal to or greater than 3mm).
- ✓ If the supply cord is damaged, it must be replaced by the manufacturer, its service agent or similarly qualified persons to avoid a hazard.
- ✓ Do not obstruct the fan or exhaust grille to ensure optimum air passage.
- ✓ Ensure adequate air return/discharge into/from the room in compliance with existing regulations in order to ensure proper device operation.
- ✓ If the environment in which the product is installed also houses a fuel-operating device (water heater, methane stove etc., that is not a “sealed chamber” type), it is essential to ensure adequate air intake, to ensure good combustion and proper equipment operation.
- ✓ Install the product so that the impeller is not accessible from the air outlet side as verified by contact with the Test Finger (test probe “B” of the norm EN61032) in compliance with the current safety regulations.

## 2.2 Responsibility of the Installer

- ✓ Correct Installation, balancing and commissioning of the unit.
- ✓ Compliance to requirements and local additional rules.
- ✓ Explanation of the ventilation system to the user.
- ✓ Warning for the user, to check or replace the air filters on time.

## 2.3 Responsibility of the Occupant

- ✓ To ensure maintenance of the ventilation unit on a regular basis. Filters should be checked, cleaned or replaced every 6 months. Details can be found on page 15 (maintenance).
- ✓ To ensure that the fan is operating. The aircycle ONE ventilation units are designed to operate 24/7.

## 3.0 Specifications/ Dimensions

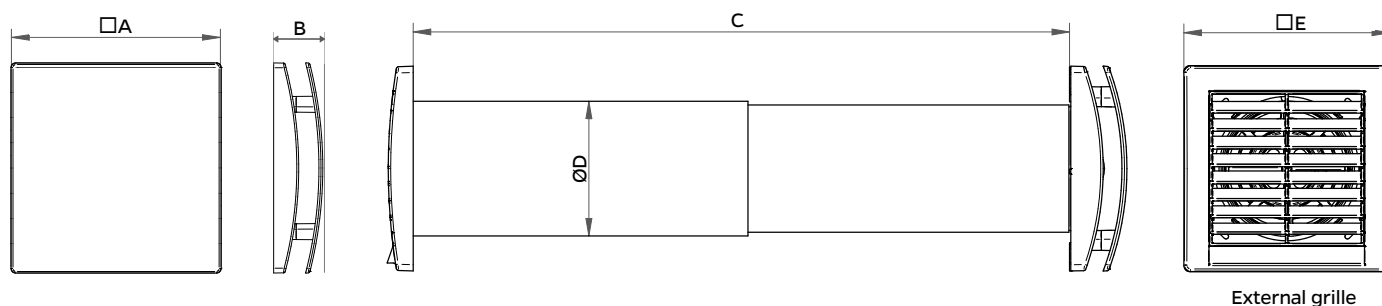

### 3.1 Product versions

Product Version	Weight	A	B	C	D	E
Fluxo 100	2.3 kg	164	46	300-570	110	164
Fluxo 150	3.9 kg	218	51	300-570	159	218

### 3.2 Detailed Specification

- ✓ Inner ventilation unit material: high quality, impact and UV-resistant ABS colour RAL 9010.
- ✓ Aesthetic front cover easily removable for cleaning without the need for tools.
- ✓ Easy maintenance installation plate, for easy access to the heat exchanger from inside the room.
- ✓ Anti-dust filter removable from inside by the tenant for maintenance.
- ✓ Regenerative heat exchanger with ceramic core; high thermal efficiency.
- ✓ External grille in high quality, impact and UV-resistant ABS colour RAL 9010.
- ✓ Unique design winglet-type impeller, providing enhanced aerodynamic properties, low noise and increased efficiency.
- ✓ Single phase EC reversible Brushless motor with integral thermal protection.
- ✓ Motor mounted on high quality ball bearings.
- ✓ The unit is double insulated: no earth connection is required.
- ✓ Trickle speed selectable.
- ✓ Boost mode.
- ✓ Free-cooling (Bypass) mode.
- ✓ IPX4 degree of protection.
- ✓ Power supply 220V to 240V~ 50Hz.

**3.3 ErP Directive - Regulations 1253/2014 - 1254/2014**

a)	Mark	-	VENTI	
b)	Model	-	FL1-100-WH	FL1-150-WH
c)	SEC class	-	A	A
c1)	SEC warm climates	kWh/m <sup>2</sup> .a	-15.6	-16.2
c2)	SEC average climates	kWh/m <sup>2</sup> .a	-37.5	-38.2
c3)	SEC cold climates	kWh/m <sup>2</sup> .a	-75.6	-76.4
	Energy label	-	Yes	
d)	Unit typology	-	Residential - bidirectional	
e)	Type of drive	-	Multi-speed drive	
f)	Type of Heat Recovery System	-	Heat recovery	
g)	Thermal efficiency of heat recovery	%	74	74
h)	Maximum flow rate	m <sup>3</sup> /h	25	60
i)	Electric power input at maximum flow rate	W	2.6	3.8
j)	Sound power level (LWA)	dB(A)	35	38
k)	Reference flow rate	m <sup>3</sup> /h	17	41
l)	Reference pressure difference	Pa	10	10
m)	Specific power input (SPI)	W/m <sup>3</sup> /h	0.071	0.054
n1)	Control factor	-	1	1
n2)	Control typology	-	Manual control (no DCV)	
o1)	Maximum internal leakage rate	%	N/A	
o2)	Maximum external leakage rate	%	1	1
p1)	Internal mixing rate	%	N/A	
p2)	External mixing rate	%	N/A	
q)	Visual filter warning	-	N/A	
r)	Instructions to install regulated grilles	-	N/A	
s)	Internet address for pre/disassembly instructions	-	www.venti-group.com	
t)	Airflow sensitivity to pressure variations	%	N/A	
u)	Indoor/outdoor air tightness	m <sup>3</sup> /h	21	60
v1)	AEC - Annual electricity consumption - warm climates	kWh	1	0.7
v2)	AEC - Annual electricity consumption - average climates jährlich	kWh	1	0.7
v3)	AEC - Annual electricity consumption - cold climates jährlich	kWh	1	0.7
w1)	AHS - Annual heating saved - warm climates	kWh	18	18.1
w2)	AHS - Annual heating saved - average climates	kWh	39.9	40
w3)	AHS - Annual heating saved - cold climates	kWh	78	78.2

## 4.0 Operation

In both versions, the unit extracts air out for 70 seconds, then it supplies air in for the same time. When heated air is pulled (extracted) from inside the room, it warms up the heat exchanger; when the cold air is pushed (supplied) in the room, it gets preheated, recovering most of thermal energy which would be otherwise lost in the ventilation process.

The unit runs at the speed selected by activating the switches “S1”, “S2” and “S3” of the Air Controller (accessory fig. 57). The same functionality can be achieved with Air Controller or with 3 switches.

S1	S2	Operation	S3	Operation
0	0	Off		Heat Recovery (Alternate flow)
I	0	Speed 1		Free cooling
0	II	Speed 2		
I	II	Speed 3		

S1

S2

S3

S3 switch activates the “Free cooling” (Bypass) mode, which stops alternate flow and keeps the fan in “extract-only” or “intake-only” mode, to avoid the heat exchange when necessary. To set the “extract-only” mode or “intake-only”, place the integral jumpers as per fig. 20A-20B. The front cover LED indicates when the Free cooling mode is on.

An automatic “Boost” mode can be achieved through a dedicated switch or room sensors like humidity sensor, CO2 sensor, PIR sensor, connecting such switch in parallel to the S2 switch.

Wiring diagram of one unit: fig. 18A.

Wiring diagram with ambient sensors: fig.18B-18C.

Wiring diagram of two or more units: fig. 18D.

## WARNING:

Ensure that the electric wiring to L and N is done correctly; an incorrect connection will lead to malfunction or permanent damage of the fan.

## 4.1 Synchronisation

When the units are installed in pair, they must be synchronised so that when one unit is extracting, the other is supplying, and viceversa (fig. 18E-18F-18G). This is achieved by setting the dedicated jumper (fig. 20A-20B).

### RESET OF THE SYNCHRONISATION

**OPTION 1:** If two or more units are connected under the same main switch, to reset the synchronisation, the main switch must be switched first OFF and then ON to reactivate (fig. 31).

**OPTION 2:** If two or more units are not connected under the same main switch, to reset the synchronisation, press at the same time the black pin of each unit (fig. 33) for at least 3 seconds.

*If two or more units are controlled by means of the same controller (Air Controller or similar), they always operate in a synchronised way. Wiring diagram as per fig. 18D*

## 4.2 Jumper positions

Intergal jumper set in position A (fig. 20A) means “extract-only” mode. Intergal jumper set in position B (fig. 20B) means “intake-only” mode.

The jumper position defines both the air-flow direction when the unit is activated for the first time (for the synchronisation) and the air-flow direction of the free- cooling mode.

## 4.3 Disposal and recycling

Information on disposal of units at the end of life. This product complies with EU Directive 2002/96/EC. The symbol of the crossed-out dustbin indicates that this product must be collected separately from other waste at the end of its life. The user must, therefore, dispose of the product in question at suitable electronic and electro-technical waste disposal collection centres, or else send the product back to the retailer when purchasing a new, equivalent type device.

Separate collection of decommissioned equipment for recycling, treatment and environmentally compatible disposal helps to prevent negative effects on the environment and on health and promotes the recycling of the materials that make up the equipment.

Improper disposal of the product by the user may result in administrative sanctions as provided by law.

## 5.0 Installation and figures

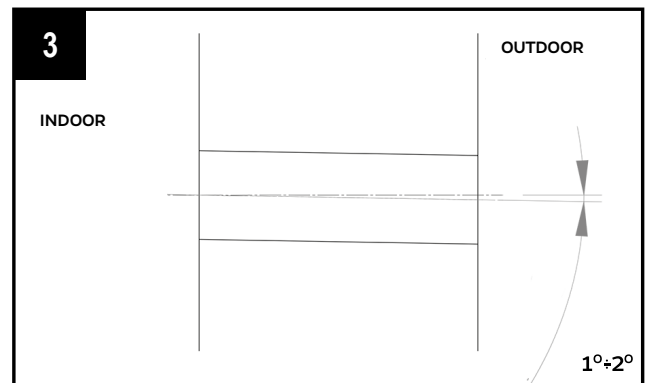
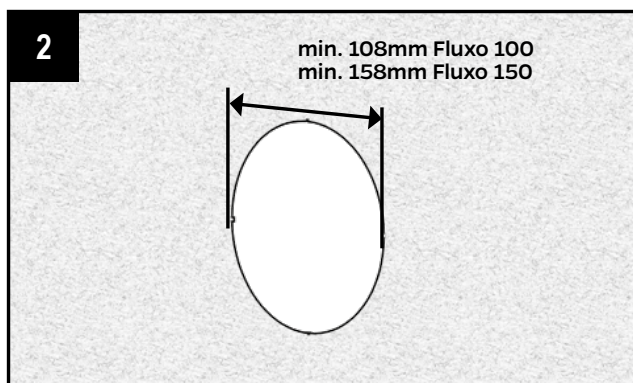
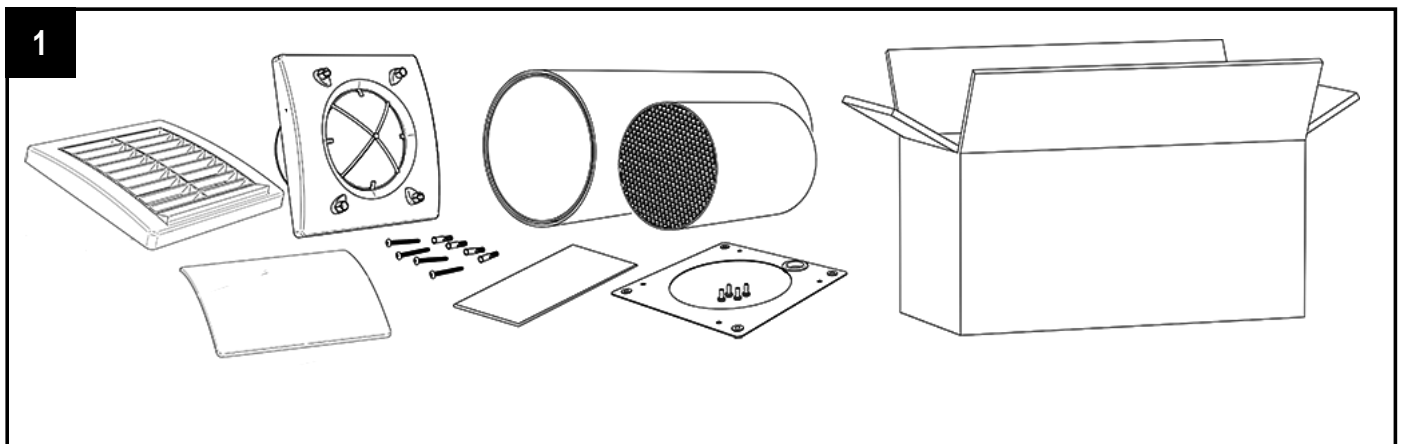



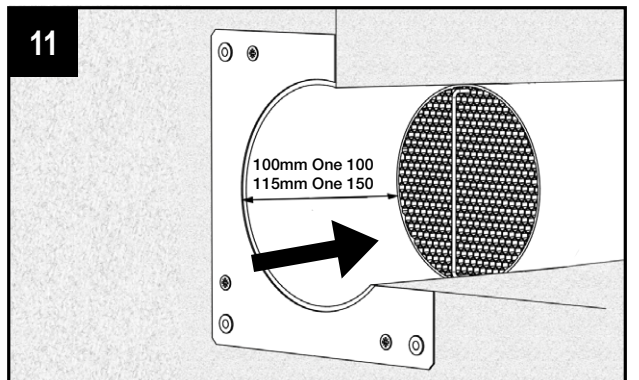
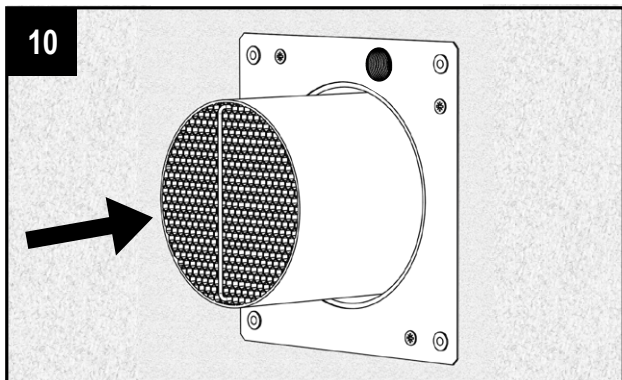
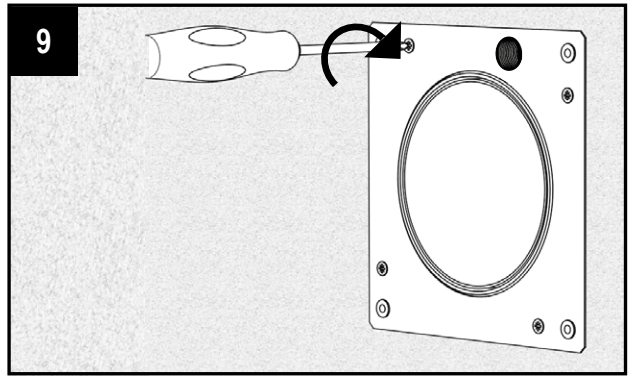
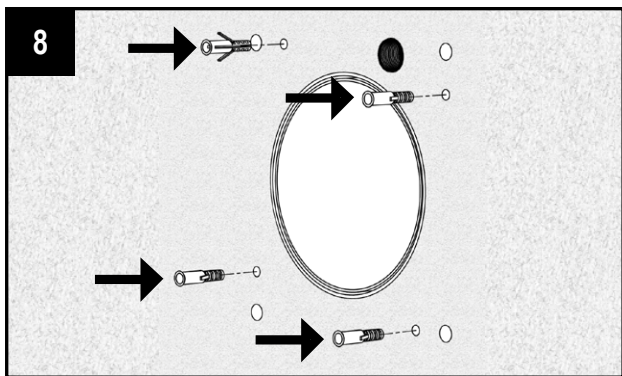
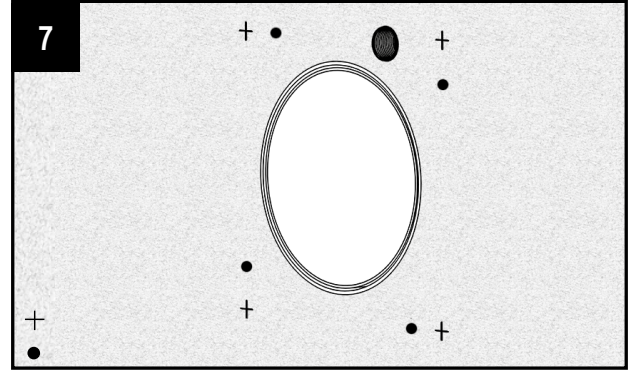
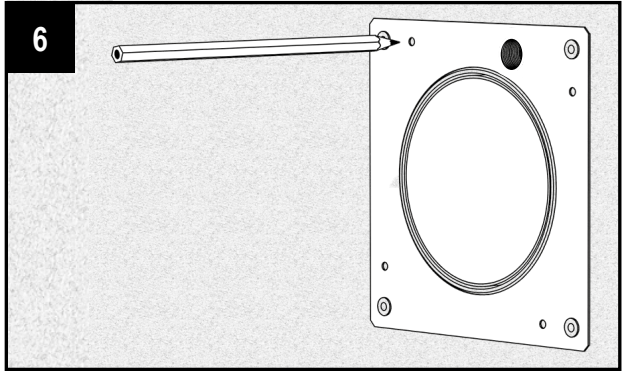
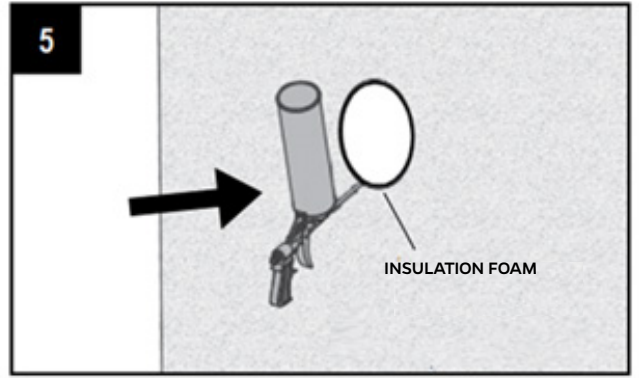
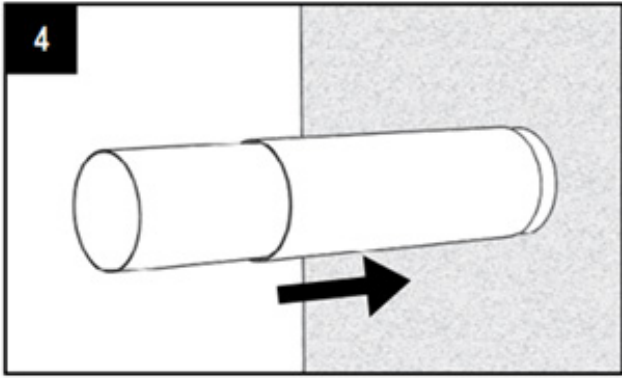

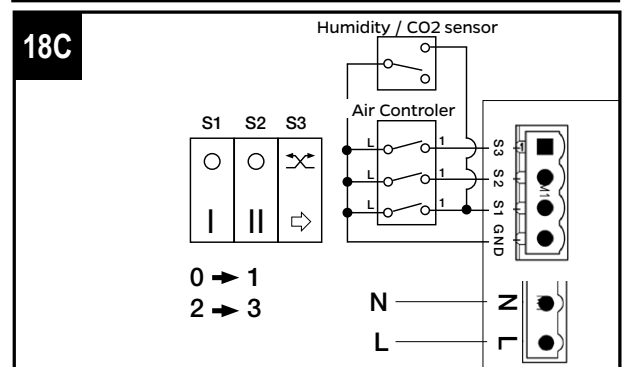
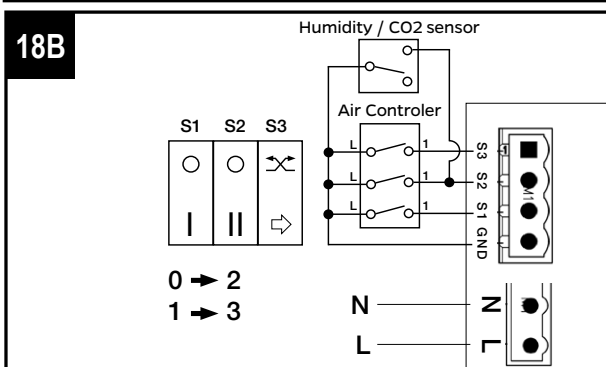
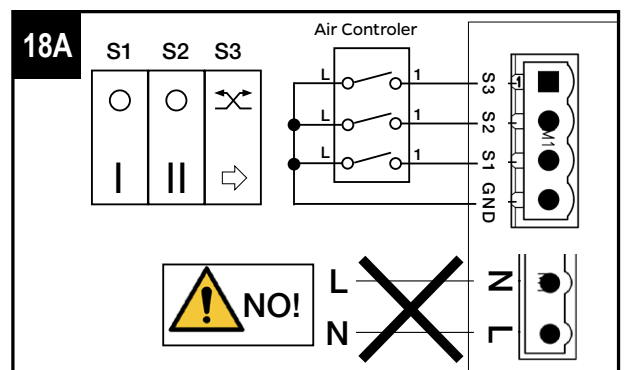
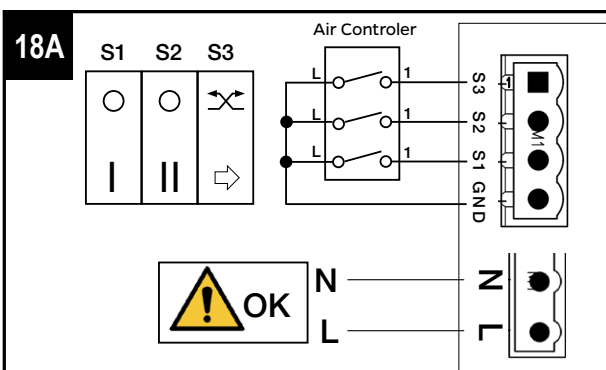
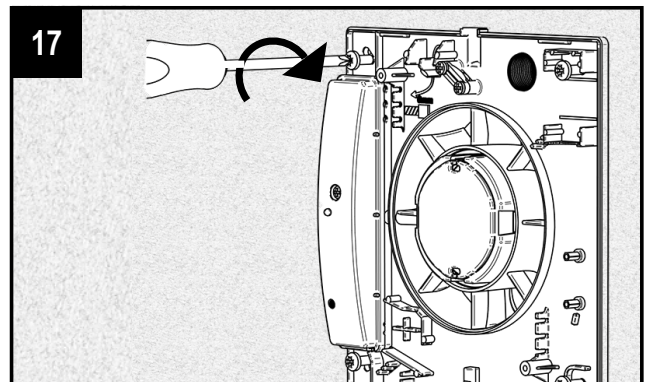
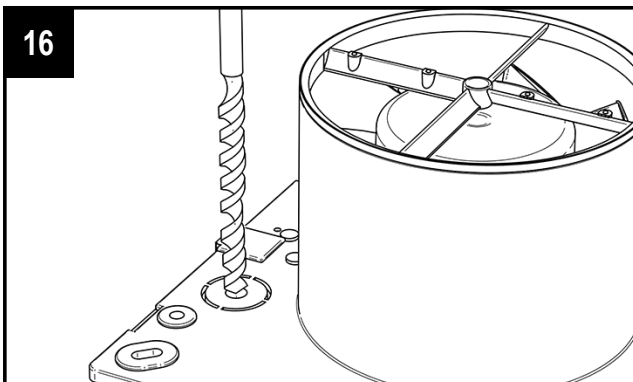
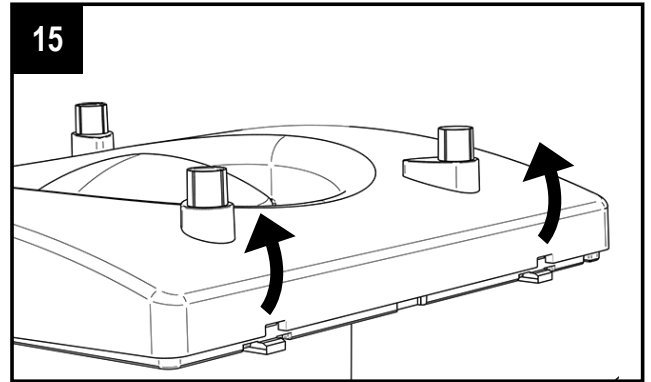
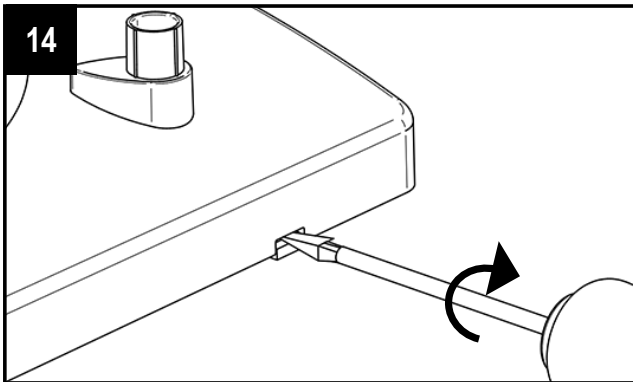
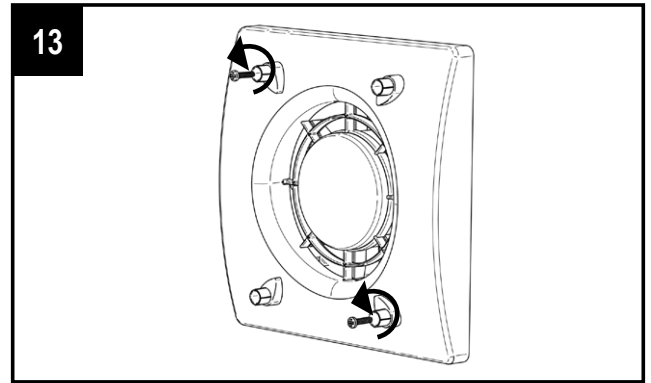
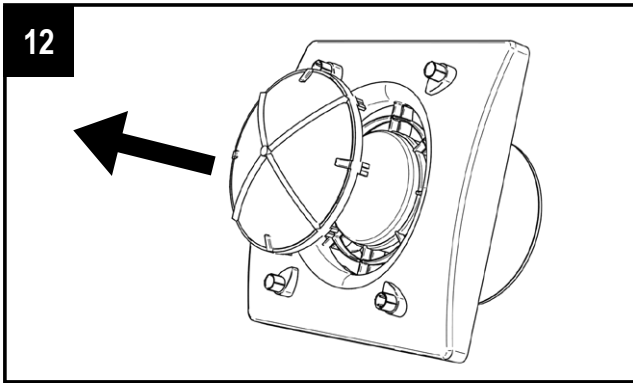

18D

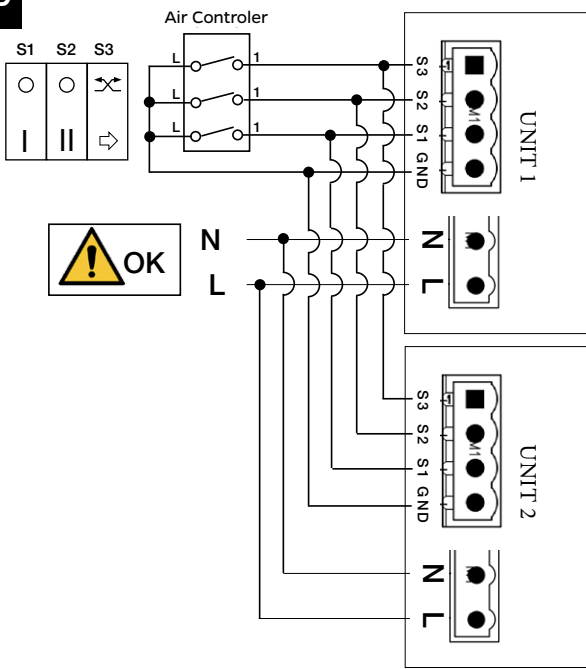

Speed 1  
(FIXED)

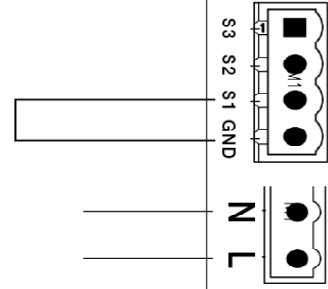

18E

Speed 2  
(FIXED)

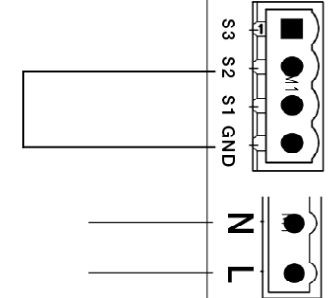

18F

Speed 3  
(FIXED)

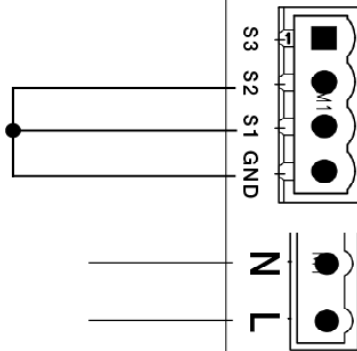

18G

19

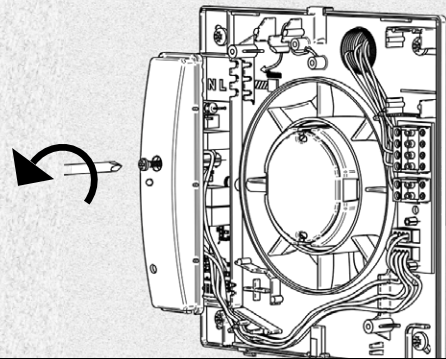

20A

JUMPER  
POSITION A

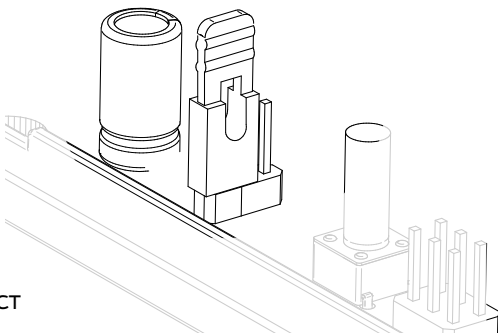

EXTRACT

20B

JUMPER  
POSITION B

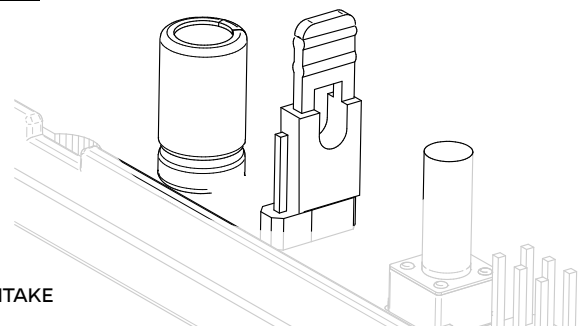

INTAKE

21

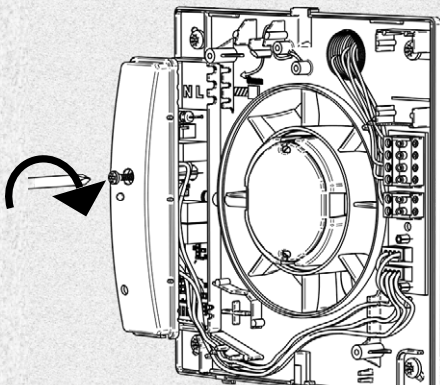

22

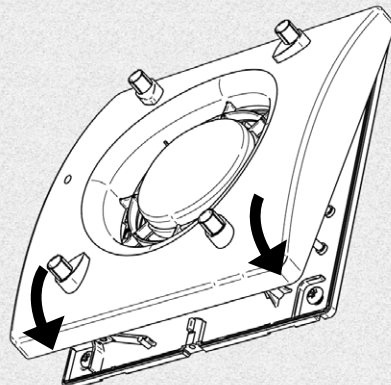

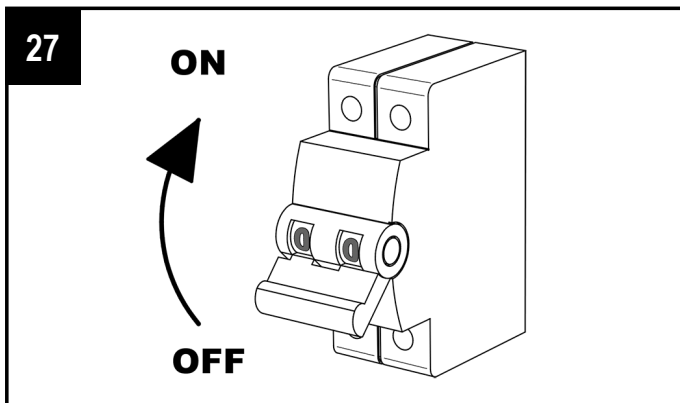
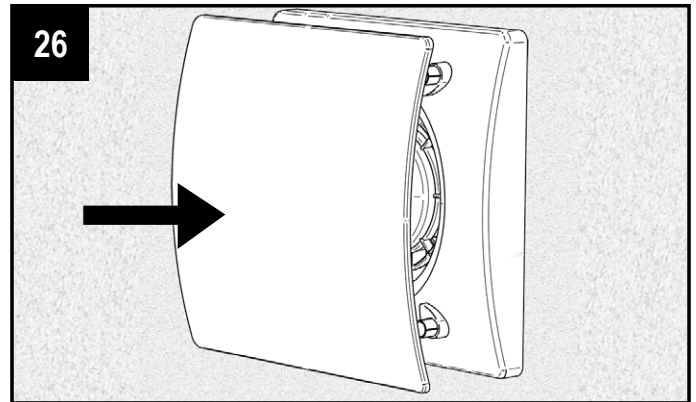
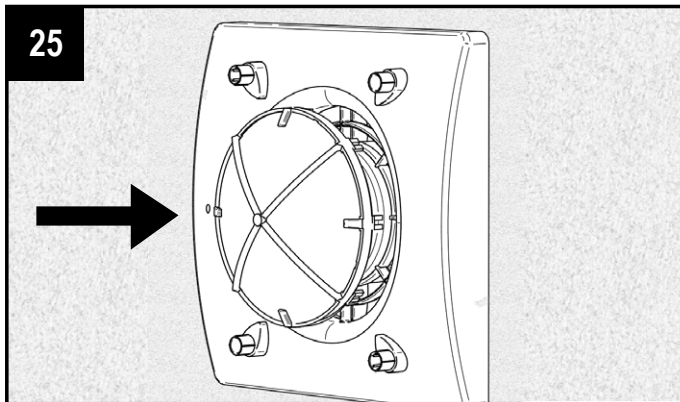
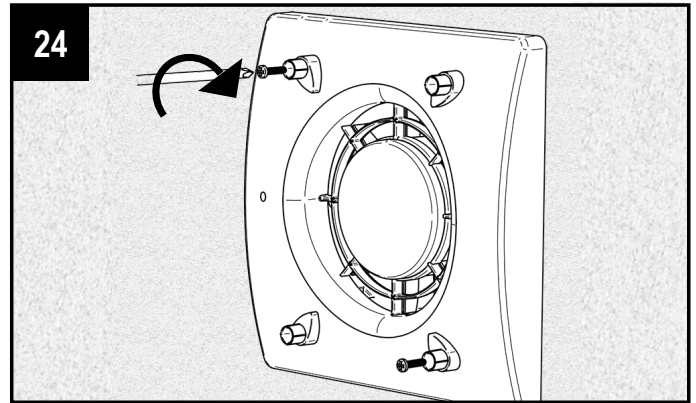
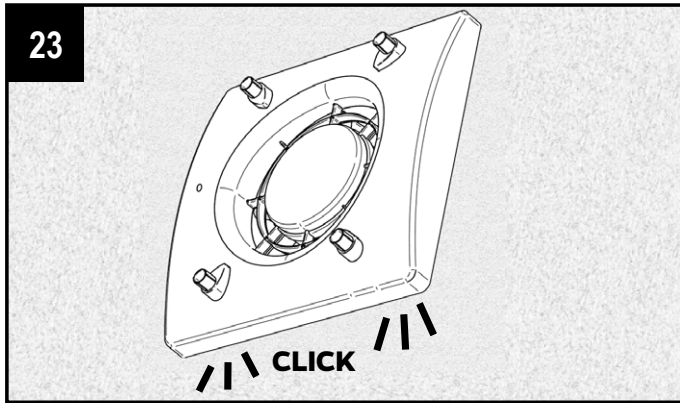

**FLUXO: EXTERNAL GRILLE**

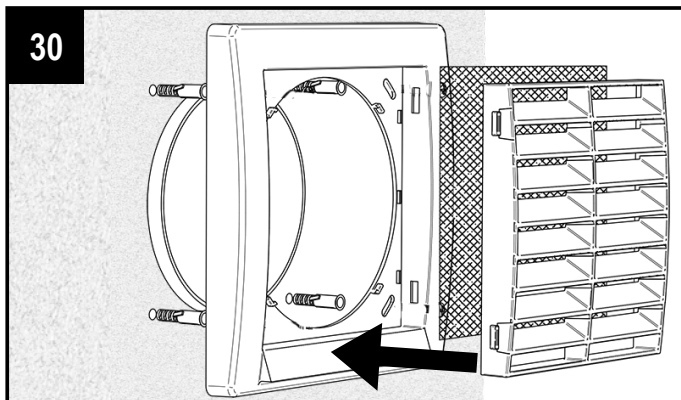
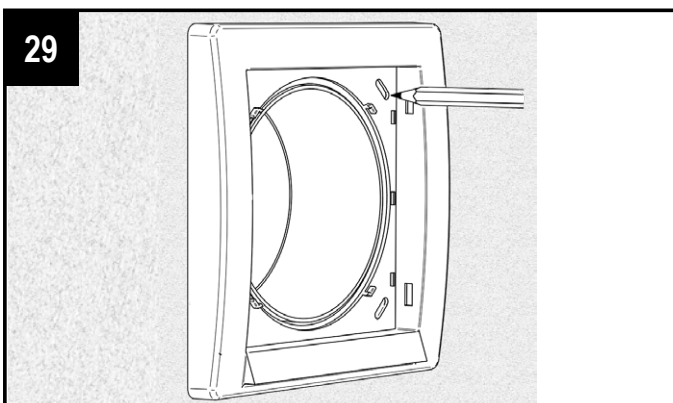
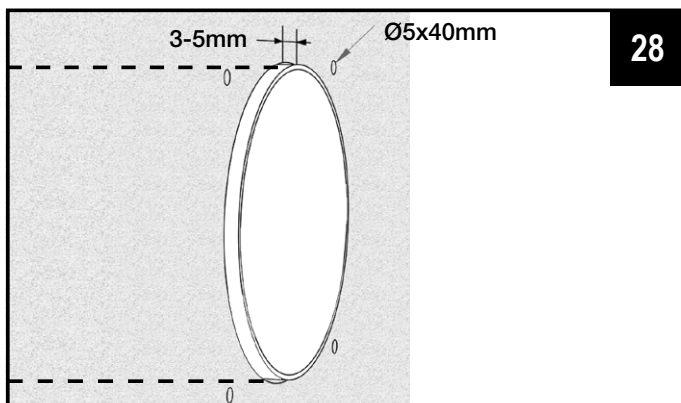

**RESETTING DEVICE SYNCHRONISATION (Option 1)**

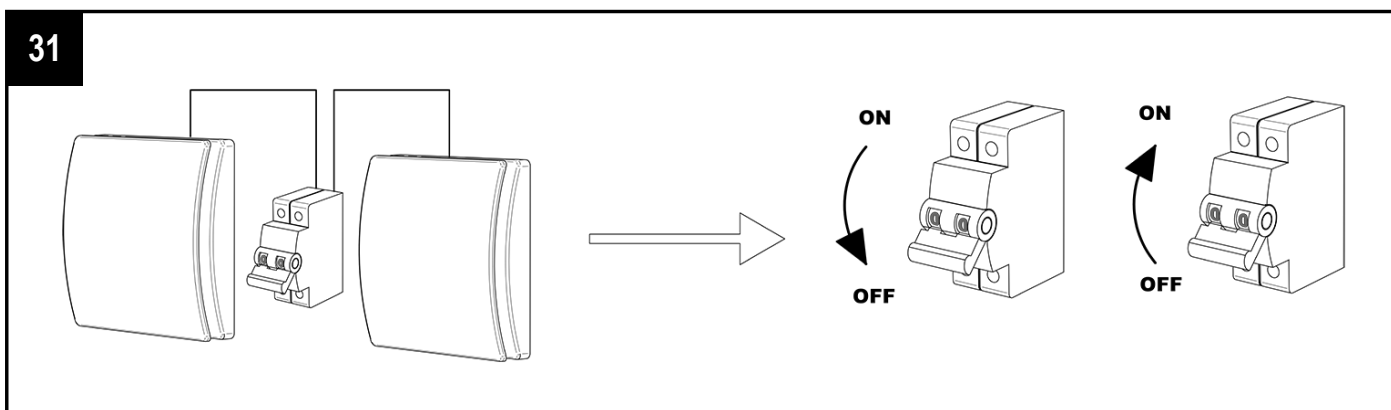

**RESETTING DEVICE SYNCHRONISATION (Option 2)**

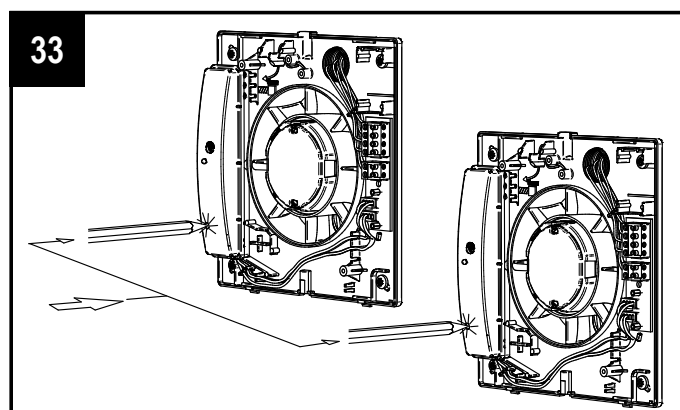
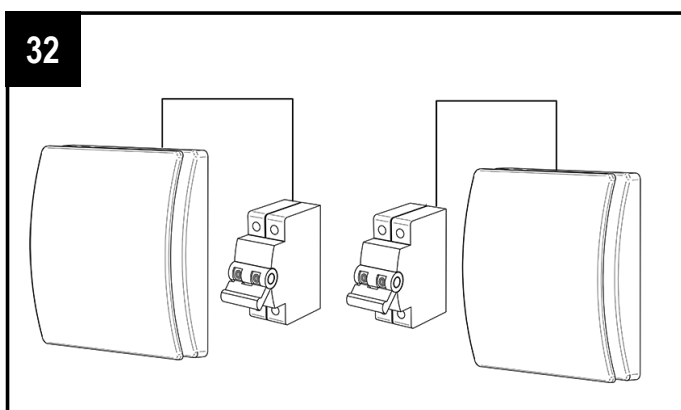

**CLEANING OF THE FILTER (MAINTENANCE)**

Can be performed by the user

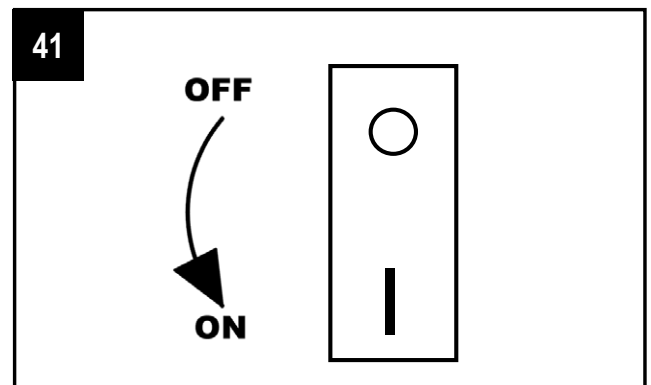
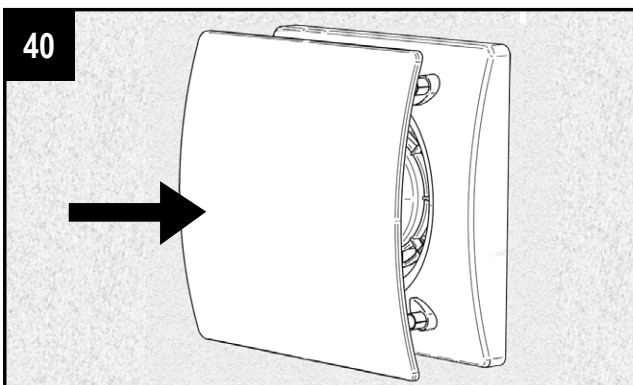
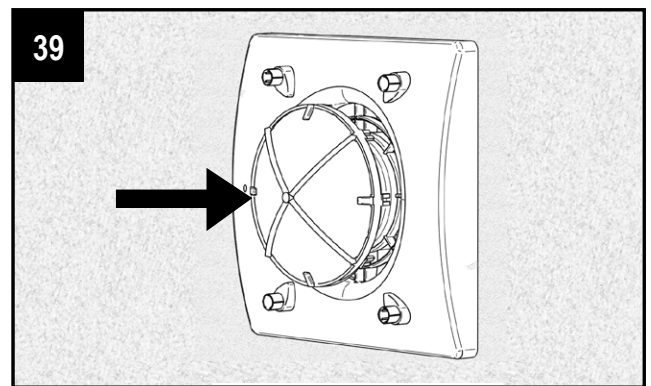
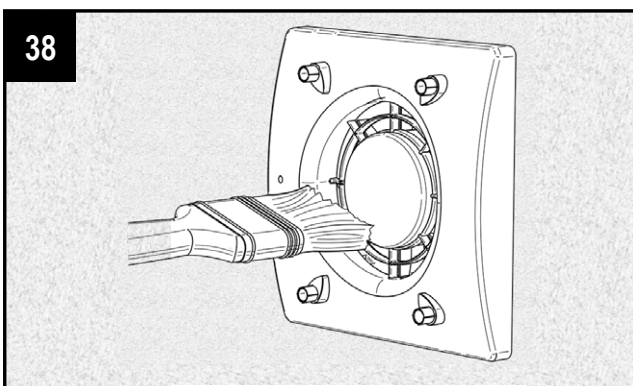
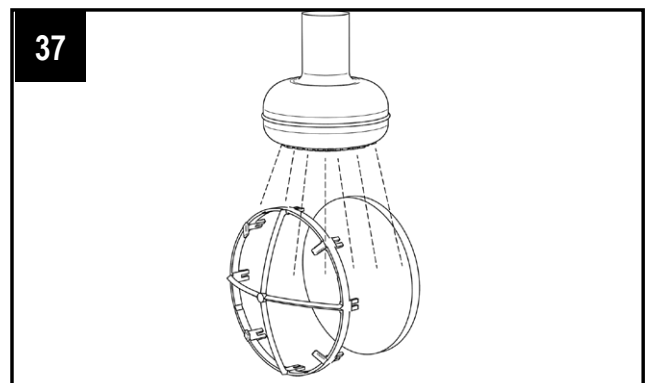
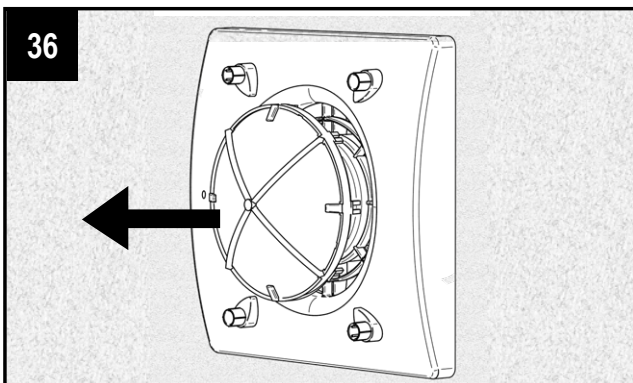
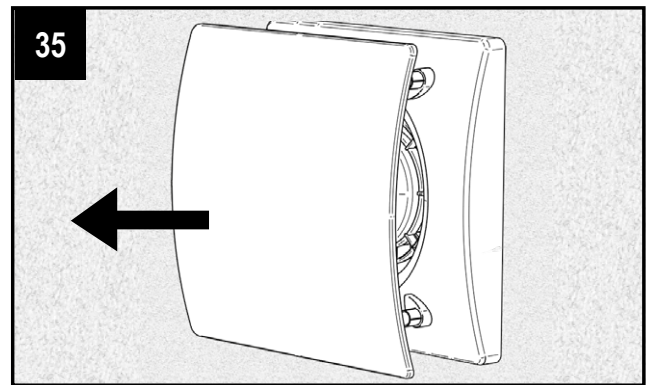
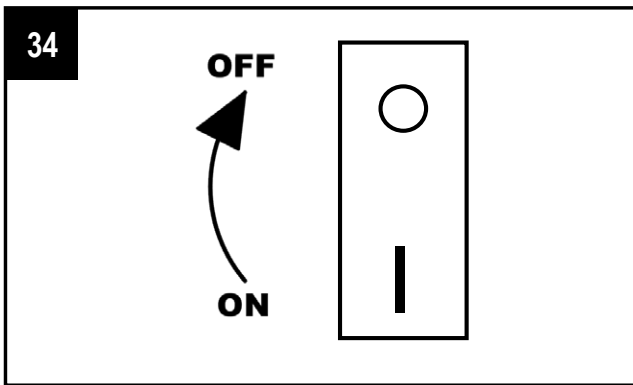

**CLEANING THE HEAT EXCHANGER**

Must be carried out only by technically qualified personnel

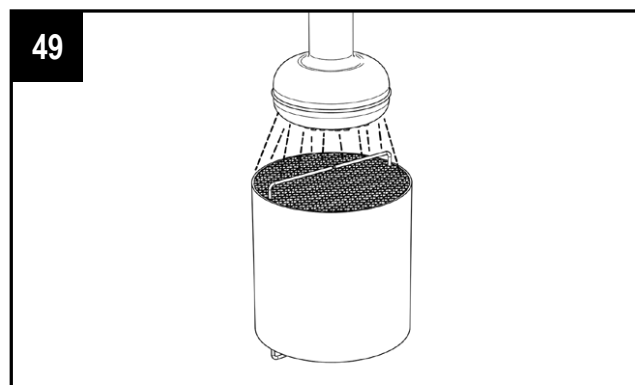
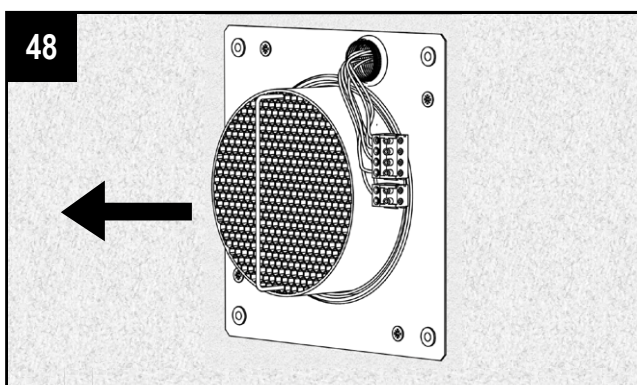
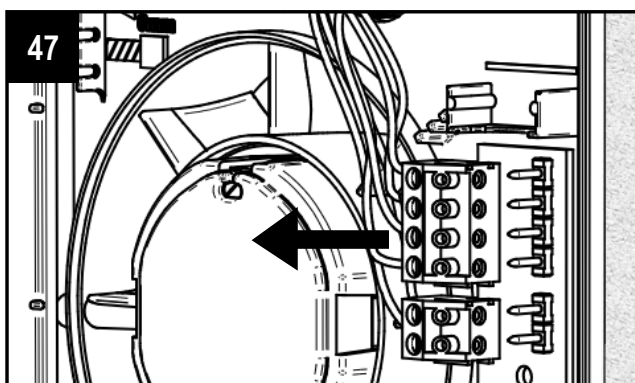
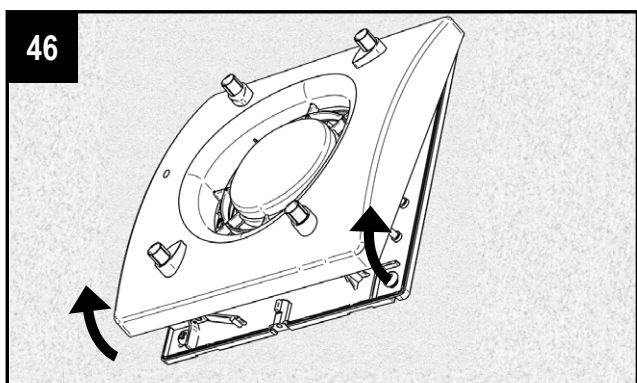
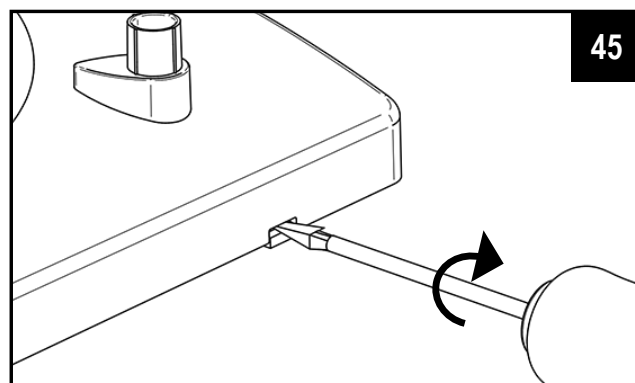
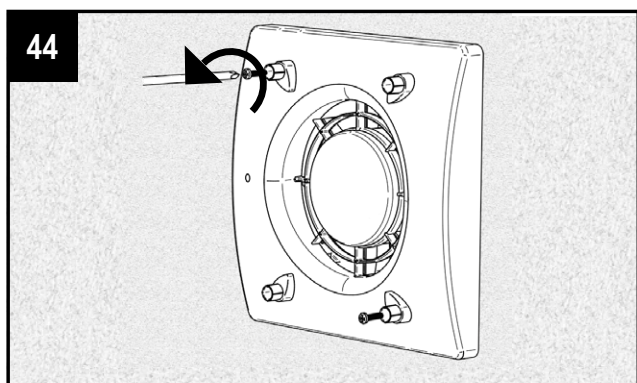
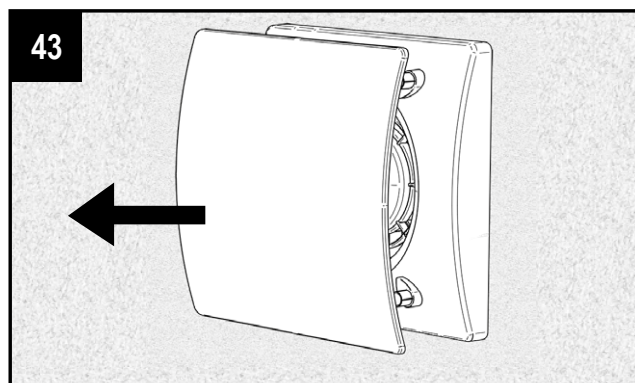
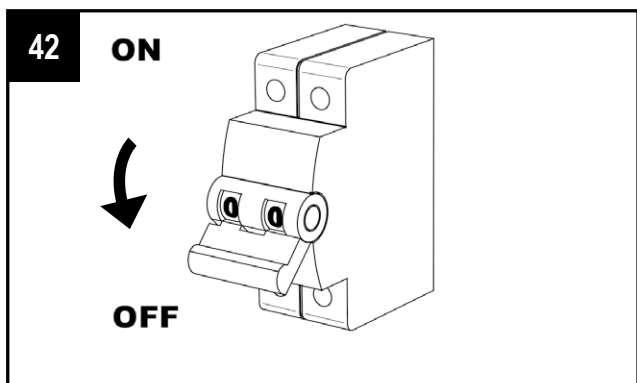

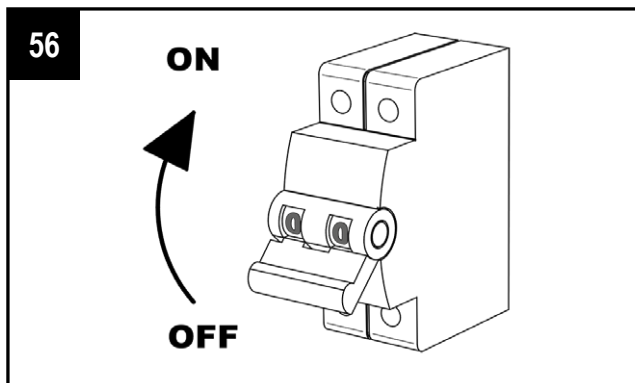
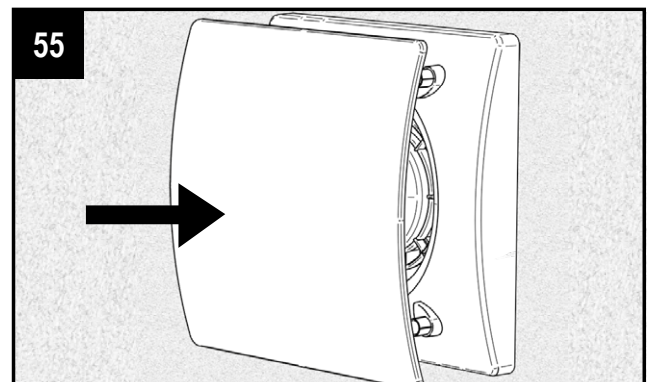
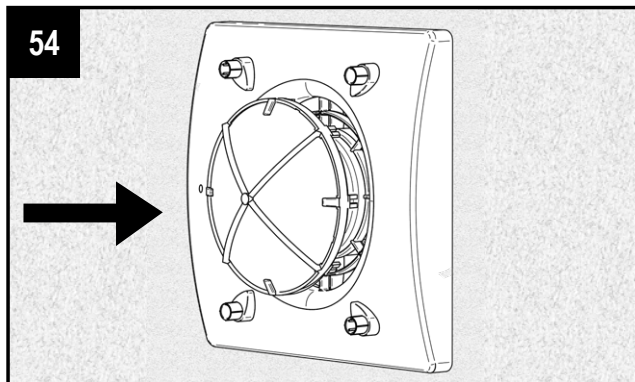
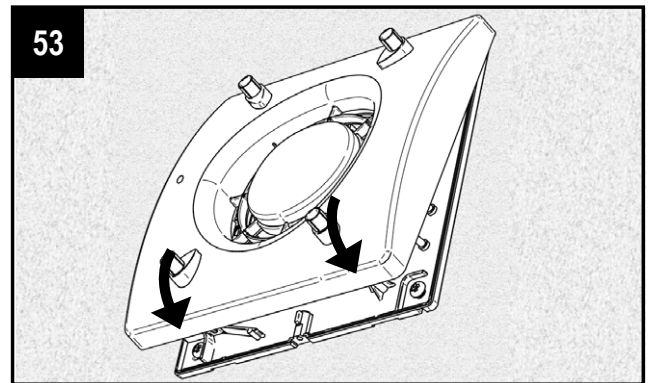
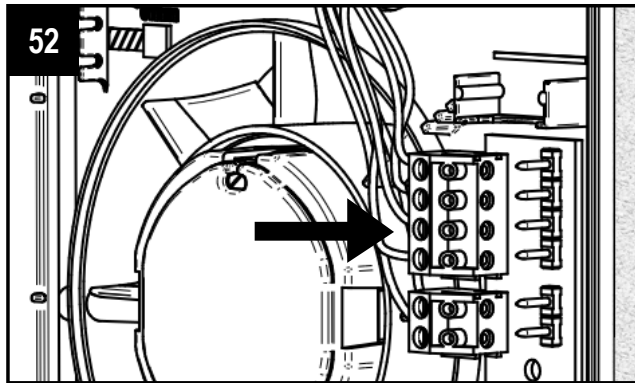
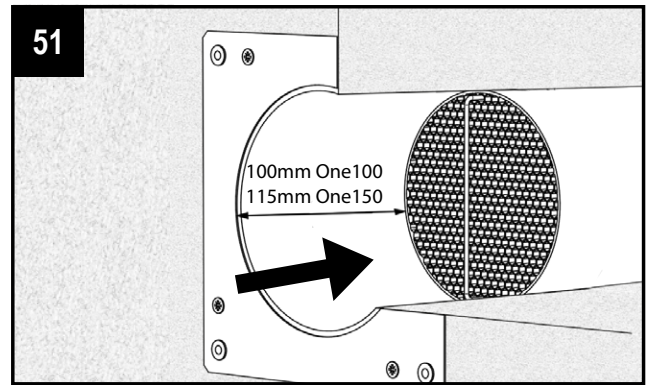
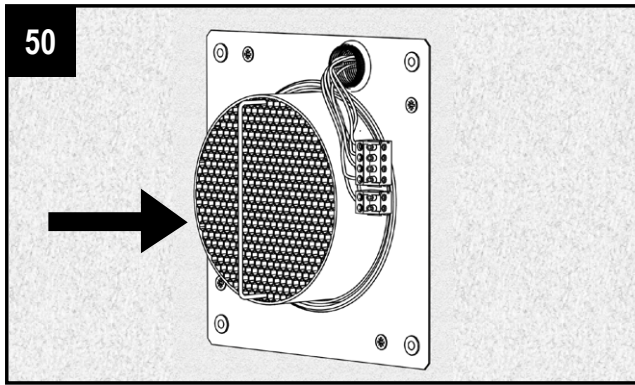



**NOTES**

VENTI™

**NOTES**

## **Customer Support**

At Venti we pride ourselves on providing Gold Standard after sales and support to all customers. Please feel free to contact one of our specialist team about any query you may have and we will be more than happy to assist you.

### **VENTI**

**Global House,  
Bojea Industrial Estate  
St Austell,  
Cornwall  
PL25 5RJ**

T: 01726 217555

Email: [sales@venti-group.com](mailto:sales@venti-group.com)

It is important to retain this manual and make a copy available to any person using or working with (maintaining) the system.

Venti operate a policy of continuous innovation and improvement and thus reserve the right to alter product specifications and appearances without notice.

# VENTI™ Fluxo